

Orion Roman Blind System



- The Orion Roman Blind System has outstanding look and performance.



Orion Roman Blind System

Unique features of Orion Roman Blind System

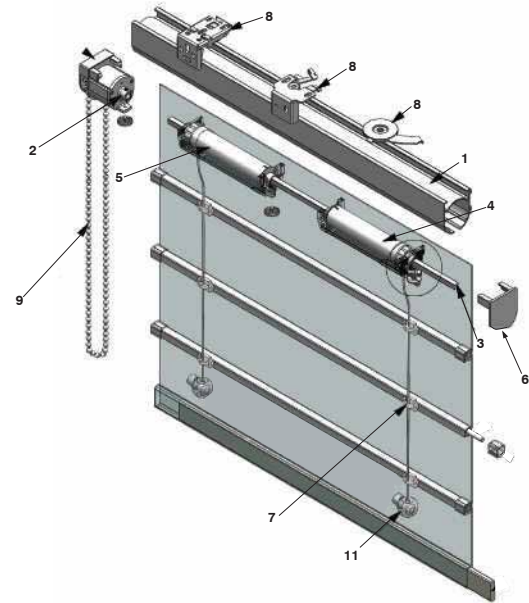

- The Orion Roman Blind System is Smooth, durable, chain mechanism for raising & lowering heavier blinds.
- Alternative finishes such as Austrian and baloon Style are also an option with this system.

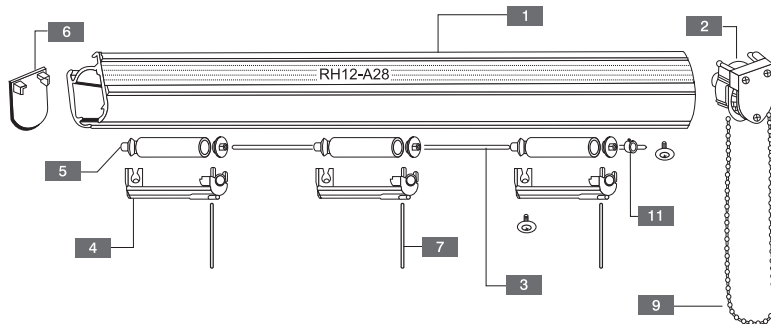

Installation Dimensions

Wall Attachment

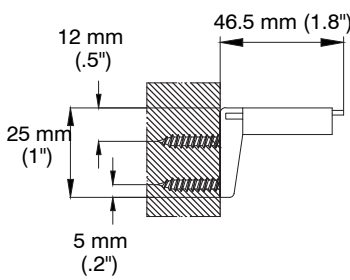

Ceiling Attachment

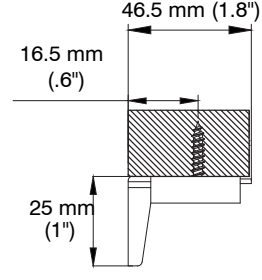

Components and Materials

Sr. No.	Product Code	Component	Material
1	ORAC01-P	Curve Track	Aluminum
2	ORAC02	Control Unit	Molded Resin
3	OH03-A5	Rod Ø 5 mm	Aluminum
4	ORA05	Drum	Aluminum
5	ORAC06	Round Shaft	Aluminum
6	ORAC08	End Cap	Molded Resin
7	OH13-13	Pull Cord	Cotton Thread

Sr. No.	Product Code	Component	Material
8	ORAC14-SLP	L Bracket	Stainless Steel
9	ORB25	Ball Chain 2.5 mtr	Stainless Steel
10	OB30	Ball Chain 3 mtr	Stainless Steel
11	OV10-YWS	Stop Ring	Brass
12	RAC-15	Valance Joiner	--
13	RAC-17P	Valance Bracket	Molded Resin